

# Fire-Cryer<sup>®</sup> Plus Voice Enhanced Sounders

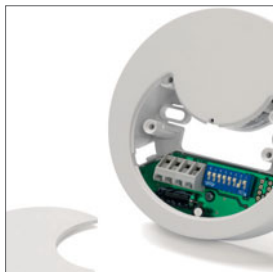
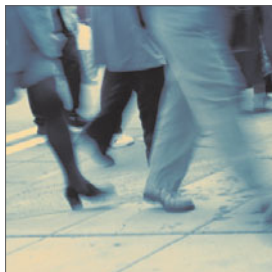

DATASHEET

**VIMPEX**

Shaping Alarm Technology

# Voice Enhanced Sounders

The Fire-Cryer® Plus voice enhanced sounder has been developed to counteract the ever-increasing problem of audible alarms being ignored. It eliminates any potential confusion by combining the normal sounder signal with a clear and unambiguous voice message.

The Fire-Cryer® Plus can be both heard and understood.

The Fire-Cryer® Plus requires no special wiring and can be retrofitted to existing installations meaning that in-situ wiring can be easily utilised. Fire-Cryer® Plus sounders are fully synchronised and have an exceptionally low current consumption allowing simple replacement of existing sounders and bells.

*“Fire! Fire!  
Please leave  
the building  
now”*



Up to seven different messages can be selected from a library of hundreds - with foreign language and bespoke messages also available. The Fire-Cryer® Plus' clarity and high sound output using the existing 2-wire installation offers unmatched flexibility and ease of use.

The need to cater for the broad range of fire protection requirements has led to an extensive English and foreign language message library encompassing a huge diversity of evacuation, alert, test and all clear messages.

**FIRE  CRYER®**  
**PLUS**

## Consultants Specification

The fire alarm and detection system should incorporate the use of voice-enhanced sounders. The voice-enhanced sounders will have the ability to produce up to seven messages using only one pair of wires per circuit and will be fully synchronised. The sounder circuit should have the ability to be monitored for both open-circuit and short-circuit fault conditions using conventional end-of-line monitoring devices.

The voice-enhanced sounders should have a low current consumption, typically 20mA, and when required, be installed within a deep weatherproof base to IP66.

The sounder system should meet the appropriate parts of British Standards BS5839 Part 1 and BS5839 Part 8.

The obvious choice for any installation where the fire alarm requires verification by voice, the Fire-Cryer® Plus lends itself to an extremely wide range of applications. Typical examples include:

## Shopping Centres

Most shopping centres have large voice evacuation systems incorporated within the PA system in public areas - but what about the individual units? The Fire-Cryer® Plus can ease confusion for the public by instructing them in a concise and intelligible manner what emergency action should be taken.

## Places of Public Entertainment

Night-clubs, concert halls and other entertainment venues can often be noisy and dark. Fire-Cryer® Plus can be utilised in conjunction with a pre-alarm such as strobes or a coded message to staff and trained personnel followed by a clear and non-panic inducing evacuation instruction.

### Case Study

Fire-Cryer® multi-message voice sounders are being used by **Odeon Cinemas** nationwide to ensure that members of the public are not confused by conventional alarm sounders in the event of an evacuation.

Standard, Midi and Maxi Fire-Cryers® have been installed in 34 of Odeon's cinema complexes throughout the UK. Maxi Fire-Cryers®, with their high-power 116dBA output, are typically positioned behind the screens providing wide coverage for the seating areas. In other areas of the cinema complexes, standard and Midi Fire-Cryers® have been seamlessly integrated with the fire alarm system.



## Museums & Galleries

The public are characteristically reticent to evacuate on hearing an evacuation signal. This fact makes voice a vital enhancement to the fire alarm system in public building such as museums.

## Areas of Mass Transit

The mass evacuation of an airport or railway station due to a false alarm is every facility manager's nightmare. The use of coded messages and time-out function in the Fire-Cryer® Plus enables a period of verification prior to general evacuation.

### Case Study

No-one in the Fire industry can doubt the commitment over the past decade of **London Underground** to improve its Fire Alarm systems. They have not only introduced leading-edge detection systems but have probably the greatest challenge in evacuation terms. Whilst below ground they have found the need for fully integrated centralised systems, in their above-ground responsibilities they have found that voice enhanced sounders meet their criteria.

The use of coded messages, as a pre-alarm to staff to take up positions and investigate an alarm immediately without initially alerting passengers, was a pre-requisite of the first installation of Fire-Cryers® for London Underground.



## Education

The advantage of using multi-message voice sounders in educational establishments is that traditional fire alarms can be mixed with everyday messages such as class change. It is common practice for schools to use the fire bells or sounders to announce class changes with the potential for confusion during a fire or routine test.

### Case Study

#### Oasis Academy Wintingham

has installed over 230 Fire-Cryer® voice sounders to ensure safe evacuation in the event of an incident. The majority of the voice sounders are Mini Fire-Cryers®, which fit discreetly beneath the fire detector bases. This means that they are very easy to install and create an overall detector/voice sounder combination with a very low profile.

## Commercial Buildings

As a 'distributed amplifier' system, Fire-Cryers® negate the need for large racks of amplifiers and high voltage cabling as used in standard PA/VA systems. Fire-Cryers® are installed on conventional sounder circuits meaning that 7-message voice systems are equally suitable for small and large commercial applications requiring several hundred sounders.

### Case Study

The tallest building in the North, **Bridgewater Place**, Leeds, has installed over 300 Mini Fire-Cryer® voice sounders. Bridgewater Place comprises of over 23,000 sq. ft. of office space located side-by-side with 200 high-rise apartments, retail outlets and leisure facilities in a prestigious development. The Mini Fire-Cryers® have been installed in all office accommodation, providing building-wide voice evacuation in the event of a fire.



## Industrial

The Fire-Cryer® Plus Range incorporates small, base-mounted sounders as well as larger horn loudspeakers such as the Maxi Fire-Cryer®. The large sounders lend themselves perfectly to industrial applications.

### Case Study

Fire-Cryer® has been employed in the historic **Rolls Royce** Barnoldswick factory to solve a critical alarm problem caused by the confusion of beeps and tones heard on site. Fire-Cryer® now allows staff to easily differentiate between the general fire/evacuation alarm and the life-critical acid spill/extractor fan failure alarms. A combination of standard, Midi and Maxi Fire-Cryers® in a special hi-visibility yellow finish were supplied. This allowed a fully switchable multi-message system to be interfaced with the existing sounder loops on site.



## Healthcare

Pre-recorded voice messages are proven to be an extremely effective means of broadcasting evacuation signals thanks to the lack of panic or emotion sometimes present in live announcements. Clear messaging is vital to safe phased evacuation. Seven pre-recorded messages facilitate phased evacuation in complex buildings such as hospitals.

# Product Overview

The Fire-Cryer® Plus family broadcasts 7 user-defined messages with 5 compatible products all synchronised on just 2 wires.

- 7 user-definable messages from a library of hundreds
- Any language accommodated
- Strobe modules allow differentiation of strobes depending alarm state
- Voice message controller makes manual message switching easy
- Scalable interfaces for complex systems

## Fire-Cryer® Plus

This voice/strobe combination allows the user to define which of the seven messages are accompanied by the flashing strobe.

- Sound output - 100dB(A)
- Optional integral strobe - red lens with red LED or clear lens with dual white and amber LEDs
- Low current - average 20mA
- No special wiring, easily retro-fitted
- Fully synchronised over multi-zones
- Deep base version available to IP66



## Mini Fire-Cryer® Plus

Slimline base sounder for discreet mounting under fire detectors. Cover plate available for wall mounting.

- Sound output - 90dB(A)
- Ultra-Slim base sounder to fit industry-standard detectors
- Omni-directional sound output
- Choice of colour to match detectors
- Installer-friendly connections
- Suitable for ceiling or wall mounting
- Optional front plate for stand-alone use



**VIMPEX**

Shaping Alarm Technology

## Midi & Maxi Fire-Cryer® Plus

High-powered voice sounders designed for less hospitable environments such as industrial applications, large open spaces like warehouses and factories, and areas of public gathering or transit.

- High output up to 116dBA
- Rugged and weatherproof enclosures
- Low current - average 100mA
- Ideally suited for open areas and noisy environments



## Ani-Mate® Fire-Cryer® Plus

True (sub 400Hz) animal-friendly sounder which is suitable for use in areas that house mammals sensitive to standard electronic sounders. The Ani-Mate® can also be used as a tone-only sounder.

- Sub 400Hz frequency designed to minimise stress to animals
- 24Vdc operation means easy interface to existing systems
- Low power consumption
- Attractive, low profile design
- Wide volume control - 83 to 92dBA



## Fire-Cryer® Plus Intelligent Strobes

Fire-Cryer® Plus strobe units address the increasing need for visual alarms to accompany voice messages in areas of high ambient noise levels or for installation in buildings in use by the deaf or hard of hearing.

Fire-Cryer® Plus Strobe units allow an amber strobe to flash during an alert message which is replaced by a red strobe the moment the evacuation message is broadcast. During 'all clear', 'test', or any one of the hundreds of other message combinations, the strobes remain off and only the voice message is broadcast. The units are also suitable for use on gas suppression systems, where a combination of red strobe and Fire-Cryer® voice sounder is fitted to the module. The red strobe will flash during the first, second and third stage alerts but will cease when the 'all clear message' is broadcast.



With extended memory and an ever-growing message library, the Fire-Cryer® Plus is suitable for many diverse applications. The new message switching PCB will accept inputs from many types of different control equipment, manual inputs and programme contacts:

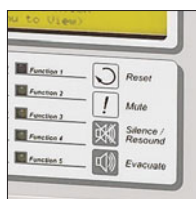

Evacuate, alert and test



Panic Alarm

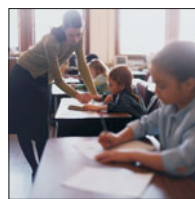

Class Change



Bomb Alert

Here is an example of a typical 7-message configuration:

- 1 Evacuate: Fire, Fire, please leave the building.
- 2 Alert: This is a fire alert, await further instructions.
- 3 Bomb Alert: This is a security alert, please keep away from windows.
- 4 Test: This is a system test, no action required.
- 5 All Clear: All clear, all clear, no further action required.
- 6 Panic Alarm: Urgent assistance required in reception area.
- 7 Class Change: This is a class change announcement.

With 7 messages on one sounder, there is plenty of scope for other types of messaging:

- Security Announcements
- Intruder Alerts
- Gas leakage and sensing alarms
- Extinguishing gas release warning
- Water Leakage Alarm
- Hazardous area warnings
- Fire door closing warnings
- Industrial safety applications

“ With three monitored inputs, crucial messages such as bomb alerts and panic buttons can be relied on to work at the critical moment. ”

## Multilingual Messaging

### Case Study: Multilingual Voice Sounders Improve Safety for Multicultural Community

High-output Maxi Fire-Cryer® voice sounders have been used to solve a challenging voice evacuation project at St. James Wholesale Market in the heart of Bradford. Multi-message voice sounders were identified as significant safety enhancements in the event of an incident at the market. However, justifiable concerns were raised on the question of how to clearly and unambiguously communicate evacuation or emergency messages to those workers whose first language is not English. The market is housed in a large warehouse-type building which is open on two sides. Therefore sounders that were loud enough to be heard over the hubbub of negotiating traders and delivery vehicles was also of paramount importance.



A site survey identified that not only were high-output sounders necessary to give the required amount of coverage, but also dual-lingual messages would need to be used. Many workers at the site have Urdu as their first language so to enhance safety Bradford City Council engineers specified dual language sounders. 10 Maxi Fire-Cryers®, each with three English-Urdu messages, were installed to give clear and concise instructions to the workers in the building as to what to do in case of fire or system test.

## Multi Message Switching PCB (MMSP)

To use the Fire-Cryer Plus® sounders in their multi-message mode it is necessary to send commands to the sounders to instruct them which of the seven messages they should broadcast. This is achieved by introducing the Multi-Message Switching PCB (MMSP).

The MMSP has developed into a versatile, expandable and user friendly interface to control up to seven different messages using just two cores. It is capable of handling 'One out all out' scenarios as well as phased evacuation or staged fire alarms.

It is as ideally suited to new compact conventional single zone builds, complex networked sites with many zones as well as retrofitting to existing systems. With the addition of interfaces such as the Hochiki CHQ-DSC and the Apollo SCC the Fire-Cryer Plus® can be successfully installed on addressable loops.

Each MMSP has two 2A sounder circuits which are monitored by the Fire Alarm Control Panel. The MMSP can be supplied separately or within enclosures housing the MMSP with or without a Keypad, Zone Extensions PCB (ZEP) and PSUs – see Voice Message Controllers opposite.

The primary message is usually 'FIRE' or 'EVACUATE' and is preceded by an alerting tone chosen by the user. The remaining six messages are known as auxiliary messages as any of these will be overridden by the primary message.

The MMSP has a number of inputs for switching the auxiliary messages, either from the keypad (if fitted) or external inputs, such as a relay, key-switch, IO unit, call point or similar switch. Two of the six auxiliary inputs are monitored providing the opportunity to include panic alarms and terrorist or bomb alerts.

The MMSP is installed between the field sounder circuits and either directly to the Fire Alarm Control Panel (FACP) or via a loop interface - see Figures 1 & 2 opposite.

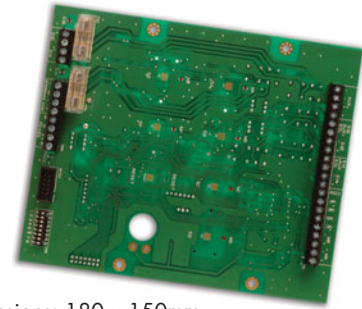

Dimensions: 180 x 150mm

### Options

There are a number of software options available at time of ordering, including:

- Pulse recognition to automatically broadcast an 'Alert' message when the sounder circuits are pulsed at 1 second on, 1 second off
- Timeout for co-incidence alarms
- Auto Cancel to automatically broadcast an 'All Clear' message if the Alert message is cancelled.

## Zone Extension PCB (ZEP)

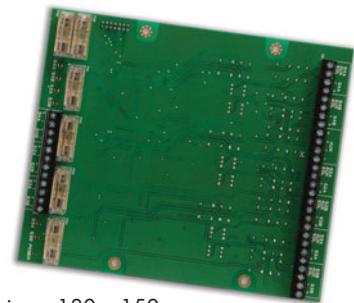

Dimensions: 180 x 150mm

A zone extension PCB is also available to seamlessly add an additional 3 zones. Each zone has two sounder circuits rated at 2A each. With the MMSP this provides up to 4 zones or 8 sounder circuits with a total load of 16A.

When the ZEP is attached to the MMSP, all messages, whether fire or auxiliary, are synchronised.

Many MMSPs can be connected together to allow for synchronisation of the primary message across any number of zones.

Each MMSP can support one Zone Extension PCB and any number of MMSPs can be connected together.



## MMSP Configuration

**Figure 1 - Direct Connection to FACP**

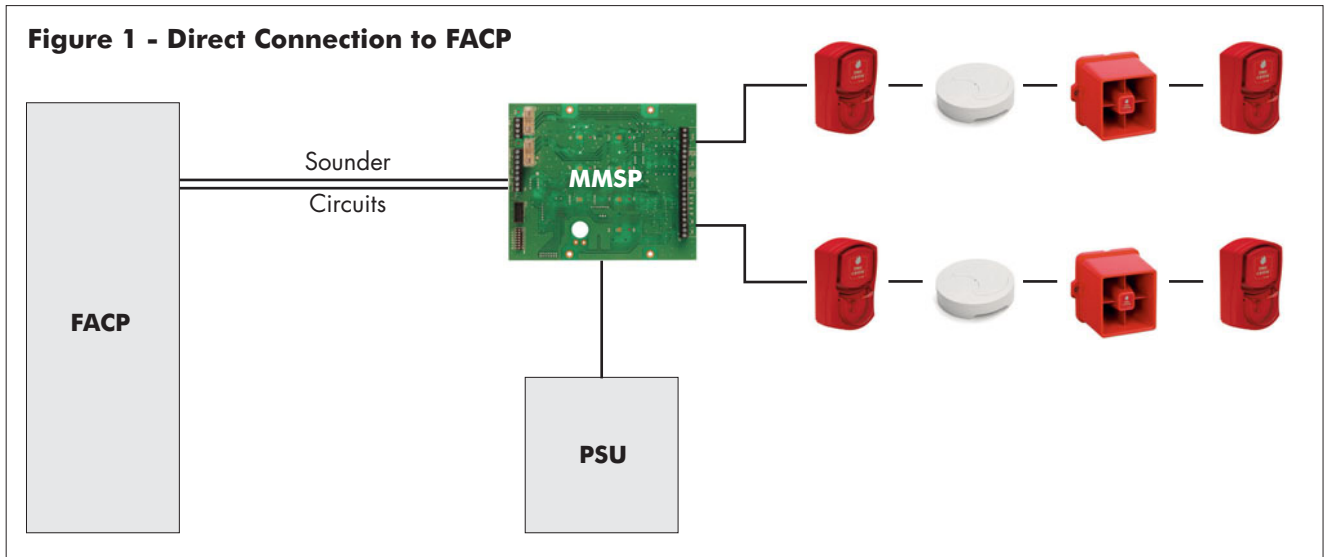

**Figure 2 - Connection via Loop Interface**

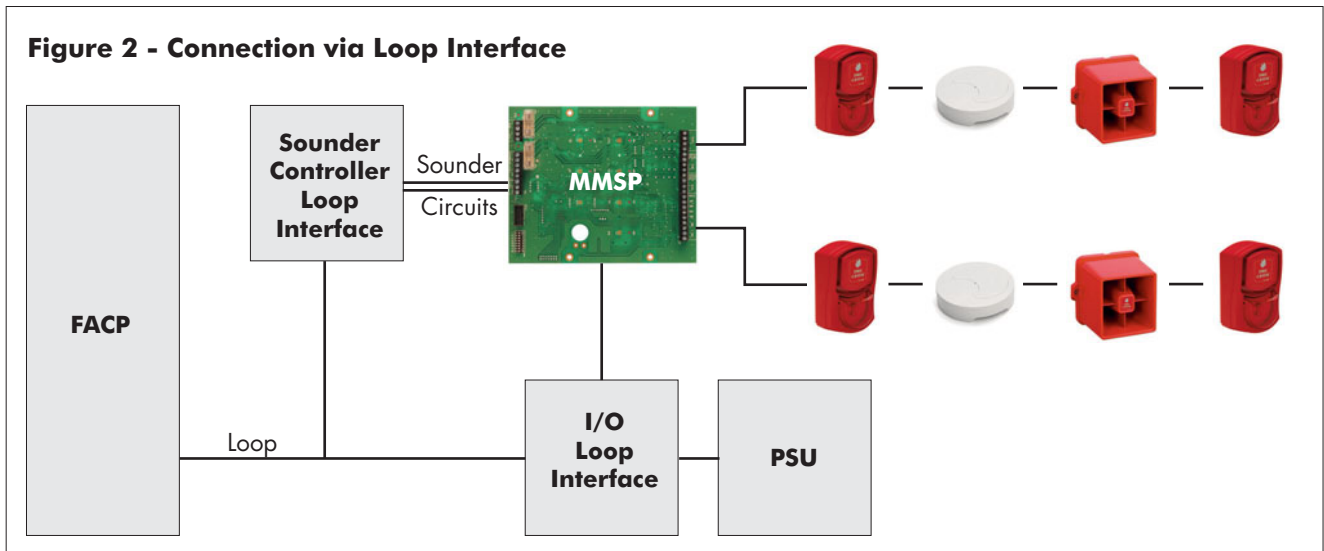

## Voice Message Controllers (VMC)

A Voice Message Controller (VMC) is a MMSP packaged in an enclosure with options for a ZEP, keypad and power supply.



**M2** Enclosure - Dimensions 385W x 310H x 90D

**M3** Enclosure - Dimensions 385W x 520H x 110D

Part Ref: VMC/\*\*/\*\*/\*\*/\*\*

- M2 or M3
- 00 = No PSU
- 02 = 2.5Amp PSU
- 04 = 4.0Amp PSU (M3 Only)
- 01 = With ZEP
- 02 = No ZEP
- 01 = MMSP with Keypad
- 02 = MMSP no Keypad

# VIMPEX

# Installation Drawings

Dimensions (mm)

## Fire-Cryer® Plus (Drawings show unit with strobe and deep base fitted)

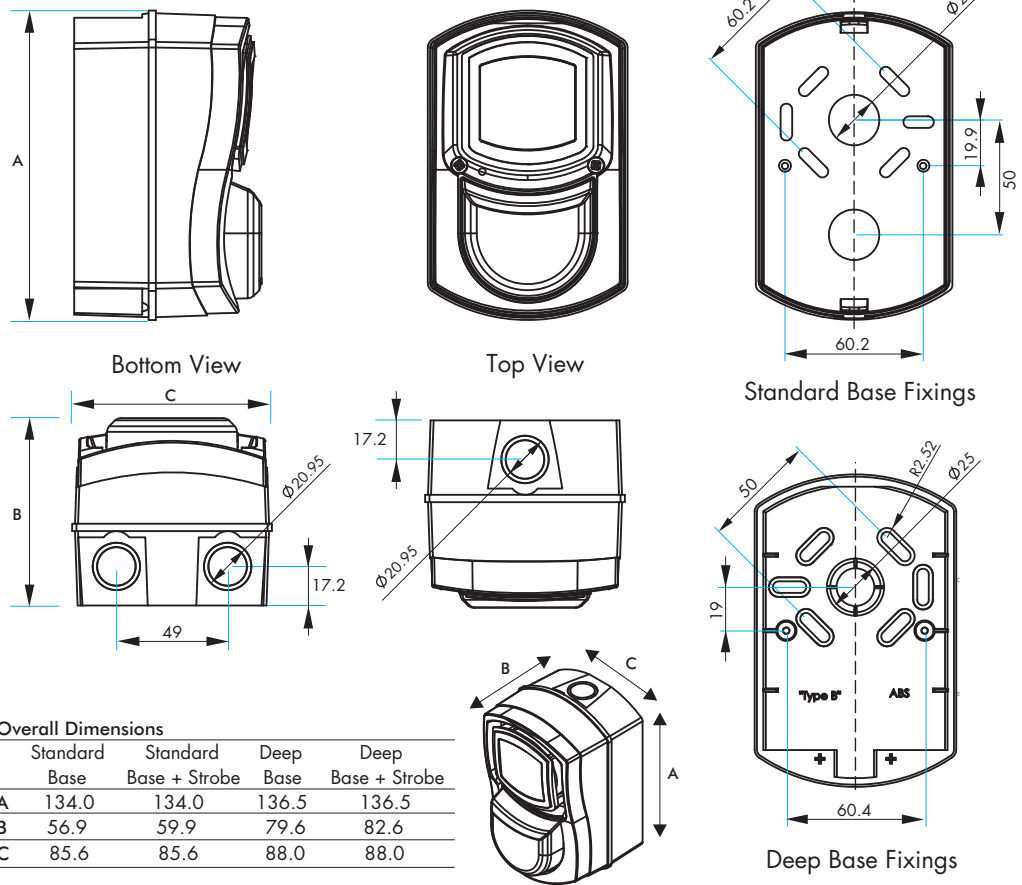

## Mini Fire-Cryer® Plus

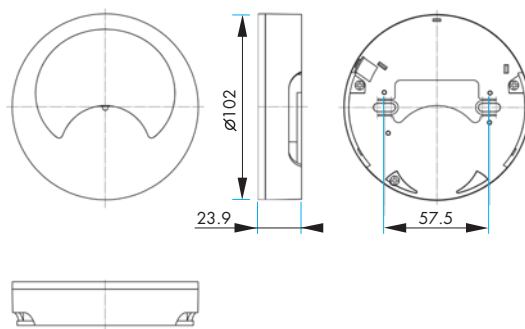

## Ani-Mate® Plus

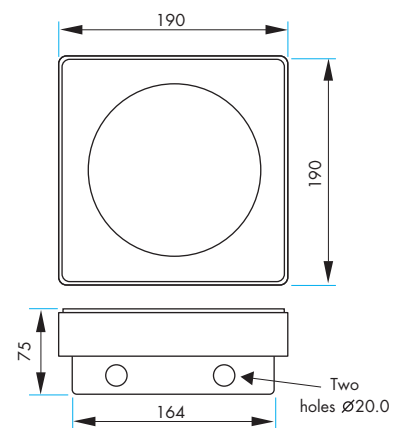

## Midi Fire-Cryer® Plus

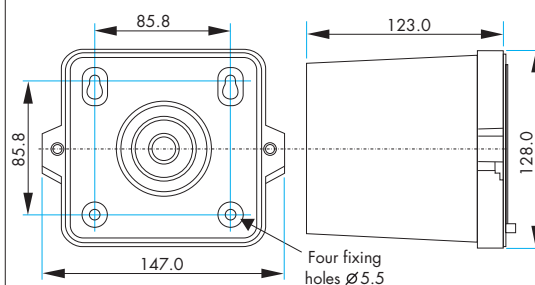

## Maxi Fire-Cryer® Plus

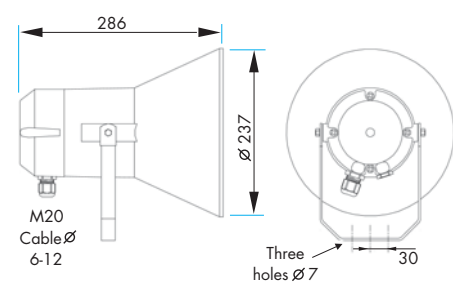

Fire-Cryer Plus® Model	Fire-Cryer Plus®	Mini	Midi	Maxi	AniMate
Part Ref	FC3/A	FC3/C	FC3/B	FC3/D	FC3/E
Operating Voltage VDC	20-28	20-28	20-28	20-28	20-28
Current mA @ 24VDC Peak/Avg - Sounder only	27/20	27/20	180/100	180/100	390/170
Current mA @ 24VDC Typical: Sounder with low current strobe	33/26	n/a	n/a	n/a	n/a
Current mA @ 24VDC Typical: Sounder with high current strobe	52/60	n/a	n/a	n/a	n/a
Current mA @ 24VDC Low current strobe only	13	n/a	n/a	n/a	n/a
Current mA @ 24VDC High current strobe only	32	n/a	n/a	n/a	n/a
Strobe Output Cd (LOW)	2	n/a	n/a	n/a	n/a
Strobe Output Cd (HIGH)	6	n/a	n/a	n/a	n/a
Effective Sound Output dBA (Typical) - Alert Fast Sweep tone to BS5839 - Voice	100 95	90 86	110 105	116 101	95 90
Volume Adjustment from Max. dBA Output to max output -18dBA	82 to 100	72 to 90	101 to 110	107 to 116	86 to 95
Weatherproofing (IP66 requires Deep Base)	IP45 or IP66	n/a	IP44	IP67	IP45
Housing Material	ABS	ABS	Aluminium/ Plastic Base	Polyamide	Steel Front, Die Cast Back Box
Temperature Range °C	-25 to +70	-10 to +55	-25 to +70	-10 to +55	-25 to +55
Colour	Red or White	White or Ivory	Red	Grey	White
Connections	Screw TB 1.5mm <sup>2</sup>	Screw TB 1.5mm <sup>2</sup>	Clamp 2.5mm	Screw TB 1.5mm <sup>2</sup>	Screw TB 1.5mm <sup>2</sup>

## Gas Suppression Systems

Fire-Cryer® Plus can be seamlessly integrated into any gas suppression system. Traditionally gas panels have utilised two sounder circuits to give different tones for 1<sup>st</sup> 2<sup>nd</sup> and 3<sup>rd</sup> stage extinguishant release warnings. The result of an ignored message could have hazardous consequences for the occupiers of the protected room.

The Fire-Cryer® Plus switching PCB can be interfaced with extinguishant control panels to give verbal warning of imminent gas release all on the one sounder circuit, thereby increasing safety at the same time as saving on wiring costs.

Typical messages used by the gas Fire-Cryer® Plus might be:

- 1st Stage extinguishant release warning
- 2nd Stage extinguishant release warning
- Extinguishant released
- Extinguishant release on hold

This combination of messages truly enhances the safety and awareness of building occupants.



# About VimpeX

Vimpex are acknowledged experts in voice sounder and audible/visual evacuation technology.

The Fire-Cryer® Plus voice sounder is testimony to Vimpex's enthusiasm for innovation and a fresh approach to evacuation.

From its highly efficient distribution warehouse, Vimpex can supply a complete range of voice sounders, audible and visual alarms and accessories. All bells and sounders can be brand labelled.

Loyalty to third party approval and testing has meant massive investment by Vimpex and its key suppliers to gain LPCB approval on a growing mix of products including the MT sounder range and fire alarm bells.

## Other Products

### The Banshee<sup>MT</sup> MT Sounder Range

The MT Range of Multi-Tone sounders and beacons represents the most modern, acoustically advanced and by far the most versatile range of conventional electronic sounders, combined units and dedicated beacons available on the market today.



### Fire Alarm Bells

The bell remains the most commonly used alarm for fire evacuation systems. Recognising this, Vimpex continue to innovate with their all-aluminium range of fire alarm bells.



### Combined Fire Bell & Strobe

A combined bell and strobe with high sound and light output to assist in the design of DDA-compliant fire systems.

### Door Holders

The Vimpex range of door holders offers the installer the broadest choice of mounting styles, holding power and installation accessories.



### Strobe Lights

The comprehensive family of 24Vdc strobe lights meet a wide range of fire and signalling applications.



### Water Detection System



The Hydrosense Water Detection System is designed to protect areas where water leakage could seriously damage electrical, communication and computer networks.

### Easy Av<sup>TM</sup> Smart Strobe Conversion

Easy AV<sup>TM</sup> is the smart way to convert existing installations of Besson's Banshee and Bedlam‡ as well as Fulleon's Roshni\* sounders to DDA-compliant sounder/strobes.



### Reset Call Point

The ReSet resettable call point is an EN54 Part 11 approved manual call point that mimics the feel of breaking glass whilst offering the user the benefits and environmental advantages of a resettable operating element.



# VIMPEX

## Vimpex Ltd

Star Lane, Great Wakering  
Essex, SS3 0PJ England.  
Tel: +44 (0) 1702 216999  
Fax: +44 (0) 1702 216699  
E-mail: sales@vimpex.co.uk

[www.vimpex.co.uk](http://www.vimpex.co.uk)



Quality System Certificate No. 456  
Assessed to ISO 9001:2000



We reserve the right to change or amend any design or specification in line with our policy of continuing development and improvement.

Part No: DS/FCPLUS/ISS 3

‡Banshee & Bedlam are trademarks of Hosiden Besson Ltd  
\*Roshni is a trademark of Fulleon Ltd